



TEREX JAQUES GYRACONE CONE CRUSHERS

- ▲ Capacities exceeding 600 tph
- ▲ High-production, low-maintenance, with the latest in cone crusher technology

Gyracone J Series Cone Crushers

The J Series Gyracone crushers have some distinguishing design features: a roller bearing mechanism, hydraulic adjustment under load, adjustable stroke, and advanced automation system (optional). These and other quality features greatly increase efficiency, reduce running and maintenance costs, increase lifetime and – most importantly – increase productivity.



The J Series Gyracones can be configured for secondary, tertiary or quaternary crushing. The machines have a wide range of crushing chamber profiles, which combine with their adjustable stroke to allow them to be adapted to a wide range of feed sizes and production requirements. Feed sizes can be in excess of 300 mm and the output in excess of 600 tph, depending on the Gyracone model and the selected feed opening. The closed-side setting is hydraulically adjusted, even under load, by raising or lowering the mantle. This gives very precise control over product size.

Terex Jaques offer total support for the life of the Gyracone crushers. Our application specialist and support engineering team can optimise your process, minimise your down-time and maximise your return on investment.

Benefits and Features

▶ **Well-shaped and uniform product**

A range of crushing profiles and speed options, steep angle crushing chamber, and adjustable eccentric throws ensure a well-shaped uniform product.

▶ **Easy maintenance**

Simple access from the top for servicing the eccentric cartridge mechanism. The countershaft is also a cartridge, allowing removal for servicing as a complete unit. The external lubrication and cooling unit allows easy access for filter and oil changes.

▶ **High production volumes**

Hydraulically supported mainshaft assembly gives fast closed-side setting adjustment under load. A pressure sensing monitor allows operation at maximum crushing pressure. Optional full crusher automation to optimise production, with the Gyracone Crusher Management System (CMS).

▶ **Adjustable stroke**

The crushing stroke of the eccentric is pre-set for the application. However it is field adjustable, so that if the duty changes, the stroke can be re-set for optimum crushing performance.

▶ **Roller bearings for high speed and low power consumption**

The eccentric mechanism is arranged with inner and outer roller bearings. The countershaft is also mounted in roller bearings. A spherical spider bearing supports the mainshaft in the top shell spider arm. Result: reduced friction and power consumption. Less frictional heating means that higher speeds can be used.

▶ **Balanced eccentric mechanism**

Counter-balanced mechanism reduces out-of-balance forces. Suitable for mobile mounting. Foundation requirements are minimised for fixed installation.

▶ **Constant mainshaft alignment**

The roller bearing mechanism and a spherical spider bearing ensure constant alignment of the shaft. Reduces wear and loss of stroke in the eccentric, and gives high output for the life of the eccentric, unlike plain bushed machines.

▶ **Fingertip setting adjustment under load**

Hydraulic control of closed-side setting, completely adjustable while the crusher is operating under load.

▶ **Tramp iron relief**

Tramp relief is handled automatically through the hydraulic system and a single accumulator. A relief valve is included, in addition to the accumulator, in order to rapidly dump hydraulic oil and lower the shaft in cases of extreme tramp iron contamination.

▶ **Rugged construction, proven in the field**

Design capacity far greater than maximum working loads. The first Gyracone was commissioned in 1970 and well-tested new models have led the field since then.

▶ **Trouble-free operation with controlled lubrication**

Automatic lubrication with external air-cooled unit. Oil temperature to the crusher bearings and gearing is controlled within fixed limits. Monitor on the oil filter. Crusher automatically stops if the oil flow is too low. Automatic motorised spider bearing grease pump.

Gyracone J Series Cone Crusher Cutaway Illustration

1. Hopper – rock box or conical design
2. Spider cap
3. Spider arm shields
4. Spherical plain bearing with automated lubrication
5. Top shell
6. Concave
7. Mantle
8. Mainshaft
9. Bottom shell
10. Dust seal bonnet and dust seal ring – combination of mechanical and pneumatic pressure sealing
11. Wear liner
12. Rib shield
13. Eccentric roller bearings
14. Balanced eccentric cartridge assembly – easily removed from bottom shell
15. Shaft thrust bearings
16. Spiral bevel gear and pinion
17. Countershaft bearings
18. Cartridge type countershaft assembly
19. Pulley
20. Piston for hydraulic shaft adjustment
21. Accumulator
22. Lubrication oil
23. Hydraulic oil



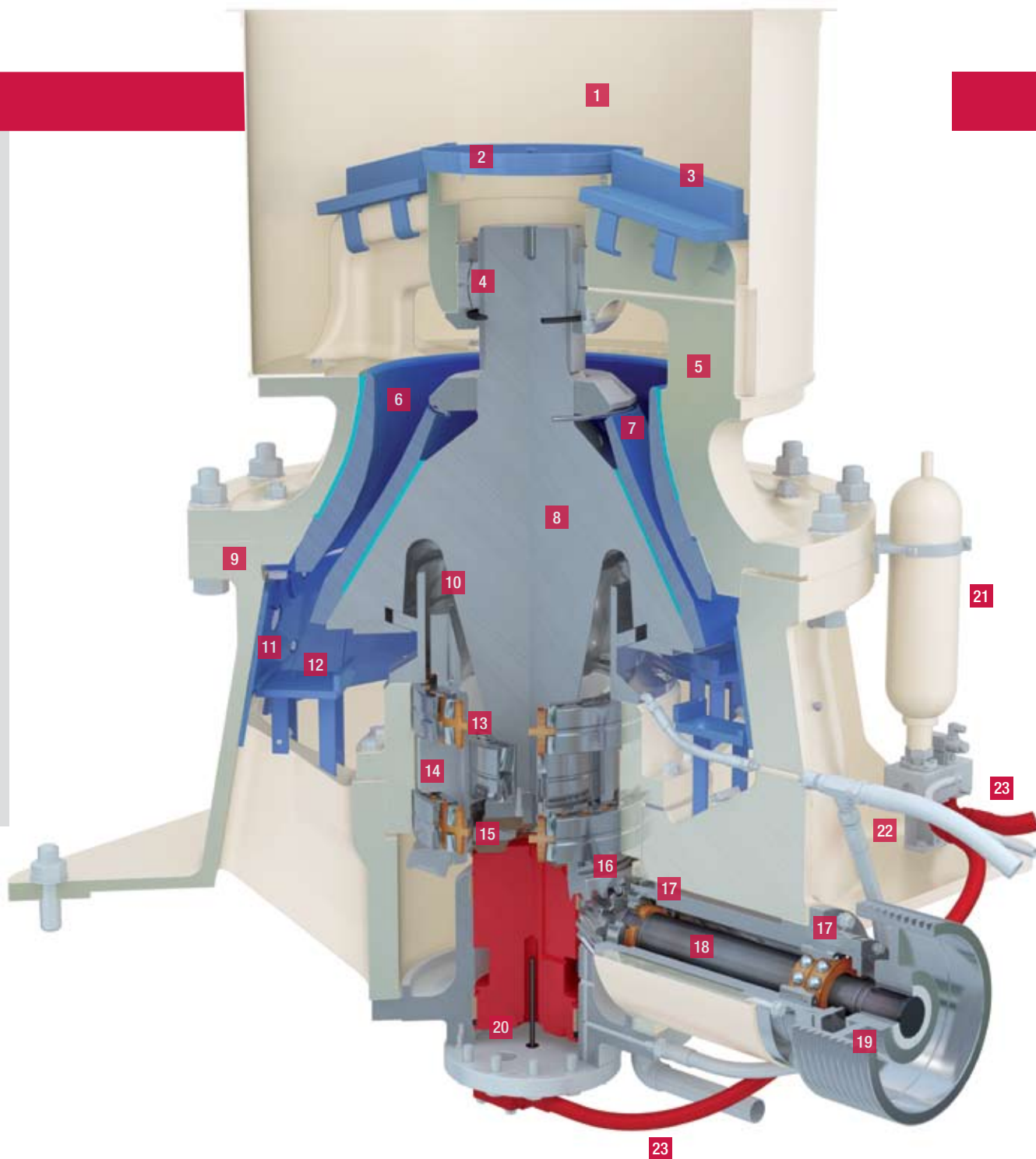

Gyracone J Series Cone Crusher Construction Details



▲ **Roller bearings for improved load-carrying capacity, efficiency and flexibility**

The Gyracone is designed for the heavy-duty crushing applications expected of a modern cone crusher. It uses the latest in heavy-duty roller bearing technology, including roller bearings in the eccentric cartridge. This gives constant geometric alignment and high load carrying capacity, with additional flexibility in speed, variable stroke and hydraulic adjustment. It is part of what makes the Gyracone a versatile and rugged crusher.

Saves power

Frictional losses in roller bearings are low. More power goes into crushing than with cone crushers that have plain bearings.

Flexibility in speed of operation

Speed, stroke, closed-side setting and reduction ratio are the main factors affecting a crusher's capacity and the product shape. With roller bearings, the operational speed is not limited by friction that could cause overheating. This means that the crusher speed can be selected to optimise product size, shape and output.

Eccentric cartridge

The eccentric cartridge can be removed readily from the top for workshop maintenance.

Low wear on bearings gives long-term performance

With low bearing wear, the stroke of the eccentric remains constant. There is no loss of capacity due to reduced stroke, unlike plain bushed machines that can lose stroke and capacity because of wear in the bushes, which can also lead to eccentric bush failure. The Gyracone's heavy-duty roller bearings give long reliable service.

Less wear on the manganese liners

Roller bearings reduce the friction on the mantle and that reduces mantle scuffing and wear.

Lubrication benefits of roller bearings

Roller bearings produce little heat and that reduces demands on the lubrication and cooling systems. In addition, roller bearings can handle high oil temperature, if there is ever a temporary lubrication failure.



▲ Hydraulic control system

Fingertip adjustment

The mainshaft hydraulic support system lets the operator adjust the crusher under load. This means that the product specification can be changed quickly or an adjustment made to compensate for the wear of the manganese liners. The operator does this by pushbutton control in the cabin. That activates valves in a self-contained hydraulic power pack, and according to the operator's choice, oil is then either pumped into the hydraulic cylinder that supports the mainshaft, or is pumped from it. The mainshaft is raised or lowered accordingly.

There are important advantages to the hydraulic control system:

- Simple, quick closed-side setting adjustment.
- The large hydraulic piston requires only low working pressure.
- Only one pump is needed, and a single hydraulic line and a control valve.

Crusher protection system

Pressure monitor (non-automated crushers)

In Gyracones that are not supplied with the optional Crusher Management System (CMS), a pressure monitor system is supplied. This system displays the hydraulic pressure on a meter that is usually located in the operator's cabin and can be linked to a plant control PLC.

The same system protects the crusher if the hydraulic pressure exceeds the recommended pre-set crushing pressure. The mainshaft is automatically lowered, opening the CSS until the crushing pressures are within the recommended level. An indicator lamp and audible alarm let the operator know this has happened. The crusher then needs re-adjustment to its original closed-side setting.

Automatic tramp metal release

If tramp metal enters the crushing chamber, it suddenly increases the crushing forces on the mainshaft. This instantly raises the oil pressure in the cylinder that supports the mainshaft and forces oil into a single gas-charged accumulator. The mainshaft then drops and releases the tramp metal. The gas pressure in the accumulator then forces oil back into the cylinder at a controlled rate and the mainshaft and mantle rise to the original CSS. In cases of extreme tramp metal contamination, a relief valve gives additional protection by rapidly dumping oil and lowering the mainshaft. The whole process is automatic, and works the same way if packing occurs. The advantage of the Gyracone relief system is that only one accumulator is required, unlike many other crushers that operate with multiple accumulators.

Clearing the crushing chamber if the crusher has stalled

If the crusher stalls under load, the operator can use the pushbutton hydraulic control system to clear the crushing chamber without manually digging out. This is done by lowering the mainshaft and simultaneously starting the crusher. The load is released and the crusher restarts, avoiding costly shut-down time.

Gyracone J Series Cone Crusher Construction Details

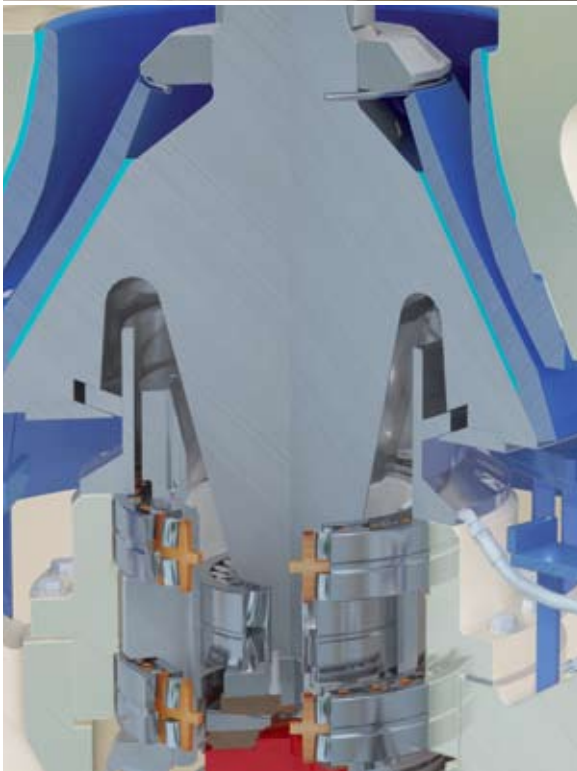

◀ Mainshaft assembly

A surface-hardened sleeve on the spider-bearing journal lets the shaft raise or lower through the bearing without galling. It also prevents wear from any rocks hitting the shaft during crushing. The sleeve can be replaced if required.

In the J35 and J50 machines, the mainshaft is a one-piece, heat-treated alloy steel forging. The one-piece design removes any potential for fret corrosion and subsequent breakage. The J65 requires a two-piece mainshaft, because of its size.

The cast manganese steel mantle has Jaques Bac epoxy between the shaft and mantle to provide support. The mantle is then secured to the mainshaft by a wear-resistant head nut. A torch ring is also fitted to assist with mantle replacement.

Dust sealing mechanism

A dust-seal ring serves as a simple but effective way to stop dust and dirt from penetrating the mechanism. The seal allows easy vertical adjustment, as well as accommodating the rotating head.

Low-pressure air is blown into the crusher mechanism for additional dust protection. An air blower is supplied with the crusher. Alternatively, compressed air is used. The air system has a pressure switch that can be connected to an alarm. It warns the operator if the air-pressure protection system stops working.

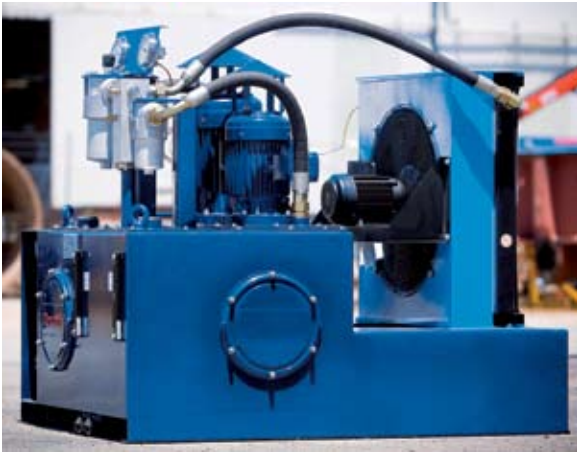

▲ Trouble-free lubrication

A motorised gear pump circulates oil from the tank to the crusher bearings and gearing. The system has a reservoir, filters, oil cooler and oil heating. The lubrication system is interlocked so that the crusher can not start unless the motorised gear pump is working and return oil from the crusher is detected.

The external lubrication system includes the hydraulic power pack and all the flexible hoses needed to connect the crusher's lubrication and hydraulic systems.

For trouble-free operation, the system:

- Prevents high oil temperature. If the oil temperature rises to a pre-set limit, the fan on the air-cooled heat exchanger turns on and lowers the temperature. If the oil temperature continues to rise above the maximum set point, the operator is alerted.
- Detects a blocked oil filter. A micro-switch in the filter body detects if the pressure differential rises above a pre-set value and alerts the operator that the filter needs to be cleaned.
- Prevents damage from low oil flow. If lubrication oil is not flowing through the return line, a flow switch in the line stops the crusher.

Spider lubrication and high-pressure warning

The crusher comes with an automated, motorised grease pump and fittings. The grease pump has a relief valve that bypasses grease through an alternative return hose and back to the grease drum if a blocked line raises the pressure. This bypass activates an output that can be connected to a visual or audible alarm.

The system has an output that can alert the operator when the grease level is low.

A timer can be set to control the grease pump, or the pump can instead be controlled by a PLC.

The pump is fitted to a lid designed for a 200 litre grease drum.

Gyracone J Series Cone Crusher Construction Details

▼ The Crusher Management System (CMS)

The CMS is an option that gives optimum control and productivity for the J Series Gyracone crushers. It is an electronic control and regulation system that automatically controls the closed-side setting (CSS) to maintain high productivity without operator intervention. It continually monitors the crusher hydraulic pressure and drive motor load, and automatically adjusts the CSS to help to prevent an overload or damage to the crusher and drive motor. Other systems are also monitored, triggering a warning or shutdown, as necessary.

A data logger in the CMS makes it simple for the operator to analyse past crushing performance. Logs are kept of the closed-side setting, power draw, pressures and temperatures. PC software is provided for either live or historical trend analysis.

The CMS has three serial ports for optional remote operation and monitoring of the crusher, either by computer or PLC. There is also modem support that can give remote access and real-time diagnostics to Terex Jaques service engineers.

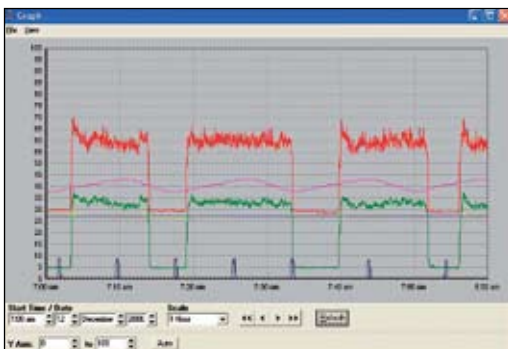

Above: CMS download graph showing power draw, hydraulic pressure, crusher setting and ancillary inputs.

Closed-side setting monitoring

The CMS continuously monitors and works to maintain the CSS selected, within the maximum crushing pressure and power limitations. It does this without the crusher stalling or working beyond its design crushing forces and gives high productivity that is difficult to maintain with only manual operation.

If either the recommended maximum crushing pressure or input power is exceeded, the CMS adjusts the closed-side setting until the crusher is operating within the maximum set power and pressure level. The crusher always works towards the selected closed-side setting, but will never close below it.

This system improves screen efficiency (reduces recirculating load) and increases the life of the manganese liners.

Automatic wear adjustment

The CMS tracks the wear trend of the manganese liners. It does this while the crusher is running and adjusts the mantle position automatically to maintain the required closed-side setting.

Data recording and remote monitoring

The CMS logs the operating data for the closed-side setting, crusher pressure, pressure spikes, oil temperature, motor power in kilowatts and operating hours. It can be used to check operating trends back in time, using either a one-second log that goes back 25 operating hours, or a one-minute log that goes back 500 operating hours.

The data can be displayed as a graph or a table, or exported to MS Excel.

Maintenance planning

The CMS calculates actual crushing hours based on power draw and manganese liner wear. The operator can interpret this data and use it to plan replacement of the concave and mantle. This can reduce downtime and parts stockholding.

Operational report monitoring

Terex Jaques can provide a report-monitoring service to help you optimise crusher availability and production. It uses the CMS and includes:

- Remotely monitoring the crusher's performance through a modem at your site.
- Using data that is logged by the CMS to recommend adjustments to the operating parameters in order to improve productivity.
- Maintenance Planning.
- Identifying reasons for crusher downtime, using trend monitoring.
- Optimising performance by assessing the uniformity of the feed within the crushing chamber by monitoring the hydraulic pressure.

This reporting does not affect your day-to-day operation. It is done at the Terex Jaques Service Centre, followed by on-site inspections when necessary.



▲ Closed-side setting indicator system

The indicator system for the closed-side setting is an option. You can choose it if you do not choose the CMS option. (The function of the closed-side setting indicator is built into the CMS.)

The closed-side setting indicator system measures the height of the mainshaft and displays either this height or the closed-side setting. The display screen would normally be located in the operator's cabin or positioned close to the crusher adjusting station.

The operator can use this system to:

- Select a closed-side setting for the crusher.
- Return the crusher to a required closed-side setting after a disturbance (shaft lowered by the pressure monitor) or after changing the manganese liner.
- Recognise when the manganese liner is reaching the end of its life and schedule a time to change it.

The system includes an alarm signal that can be used to indicate when the mainshaft reaches a set point and to limit its travel. It can also be linked into a plant control PLC.

Gyracone J Series Cone Crusher – Three Proven Models

Dimensions (mm) & weights (kg)	J35	J50	J65
A	2435	3225	4110
B	1240	1880	2600
C	1470	2285	3070
D	1180	1525	1980
E	460	715	1035
F	670	1085	1345
G	1275	1175	1470
H	1520	2285	2600
J	1760	2535	3040
ØK	1725	1790	2580
ØM	1755	2085	2470
Total Crusher Weight (kg)	10690	27500	48000
Heaviest Maintenance Lift (Topshell Assy) (kg)	2590	7100	14100

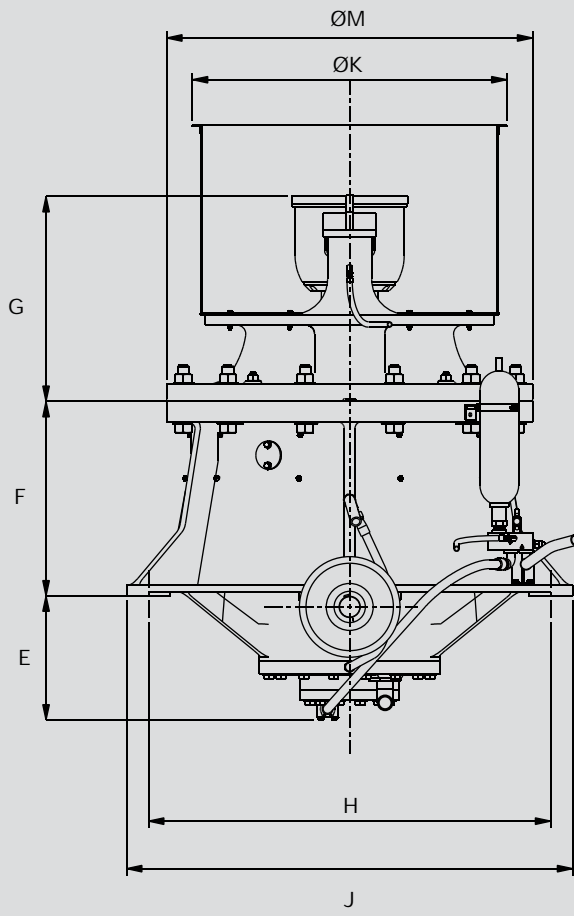
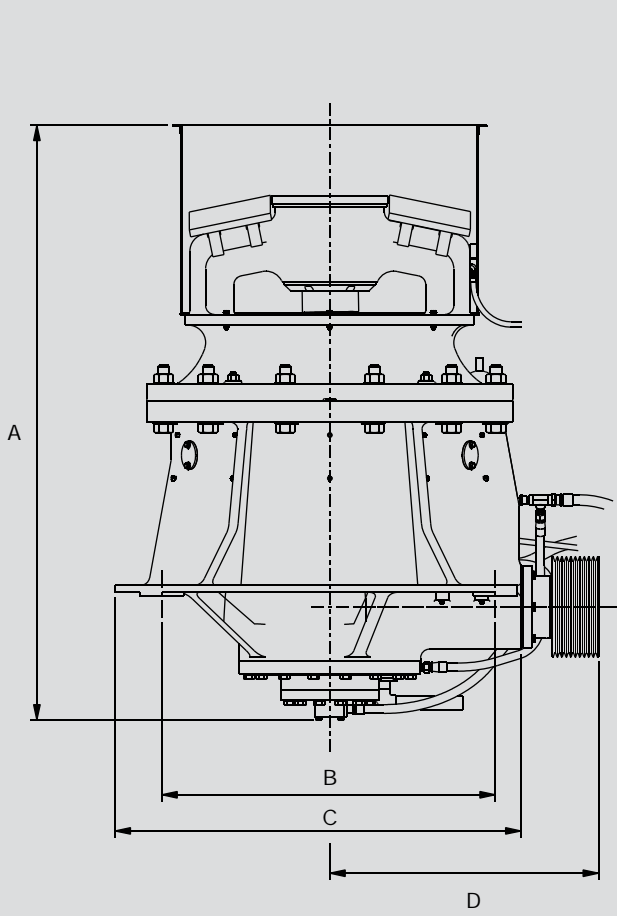

Gyracone Crushing Chamber Design

Crushing cavities are available to suit fine, medium or coarse crushing duties.

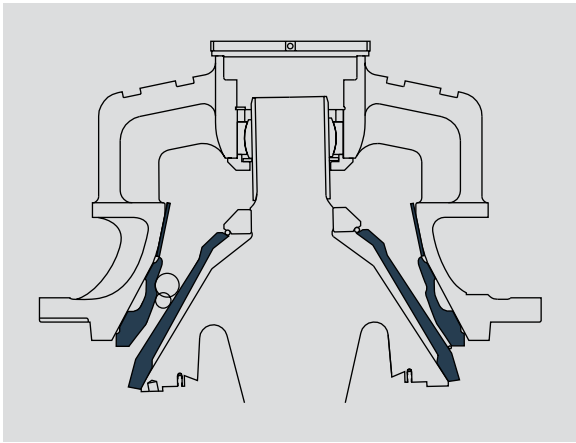

Fine crushing duties.

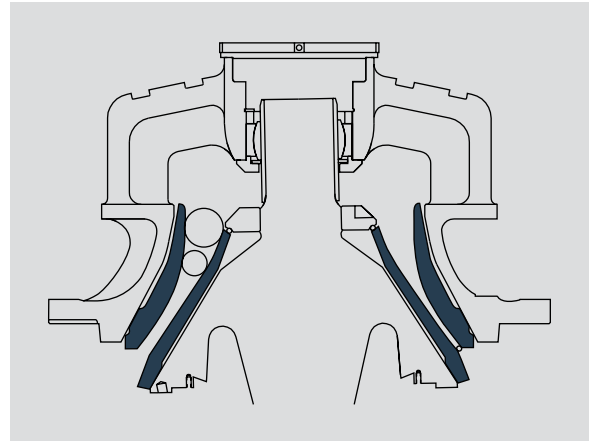

Medium crushing duties.

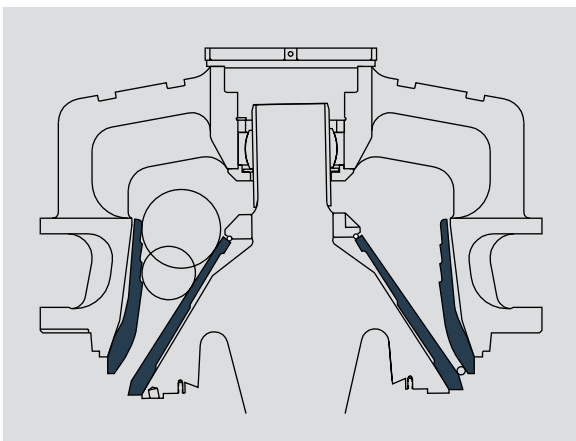

Coarse crushing duties.



Gyracone Crusher Product Gradations

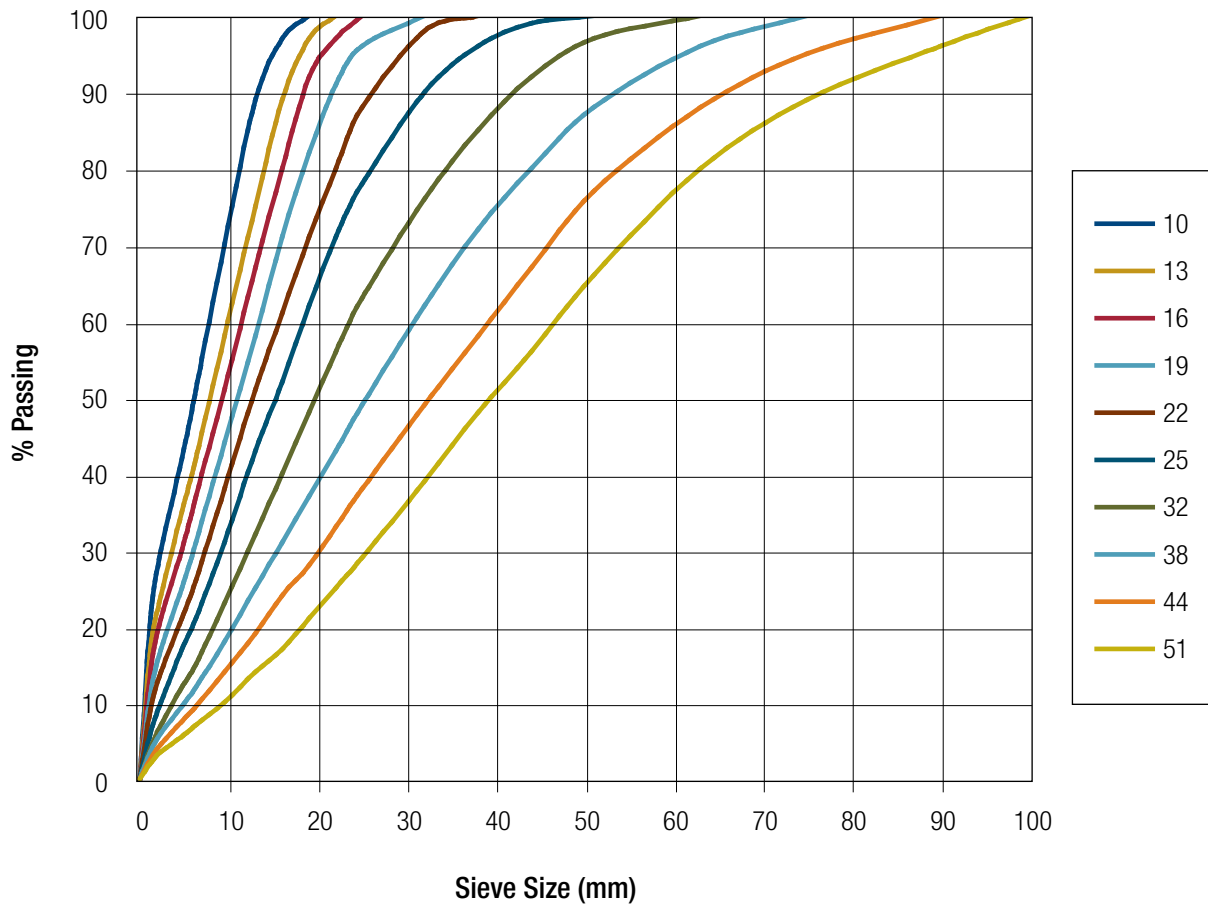

Footnote: These product curves are to be used as a guide only. Crusher product is dependent on feed material properties. Please consult Terex Jaques for advice on product gradations for specific feed materials.

Gyracone Capacity Table



Gyracone Model	Feed Opening (mm)*	Power (kW)	Stroke (adjustable)
J35	60	90	Min
		150	Max**
	90	90	Min
		150	Max**
	115	90	Min
		150	Max**
	140	90	Min
		150	Max**
180	90	Min	
	150	Max**	
J50	110	220	Min
		260	Max
	150	220	Min
		260	Max
	250	220	Min
		260	Max
	340	220	Min
		260	Max
J65	150	300	Min
		335	Max
	225	300	Min
		335	Max
	450	300	Min
		335	Max

Footnote: * Maximum feed size is approximately 75% of feed opening.

** The largest stroke option for the Model J35 is fixed, not adjustable. Other stroke options are adjustable.

Approximate throughput in metric tph (one metric tonne = 2204 lb)

Closed Side Setting (mm)

	10	12	14	16	18	20	22	25	30	35	40	50
	60-70	65-75	70-80	75-85	80-90	85-95						
	75-95	85-105	90-105	95-110	100-115	105-120						
		70-80	75-85	80-90	85-95	85-95						
		95-120	100-125	110-130	120-145	125-150						
		75-85	80-90	85-100	90-110	95-115	105-125					
		95-120	100-125	110-130	120-145	125-150	135-165					
		80-105	90-110	100-120	105-130	115-140	120-145	130-160				
		100-130	110-140	120-150	130-160	140-170	150-180	160-190				
						120-145	125-150	135-160	145-175			
						150-180	160-190	170-200	185-215			
		140-170	160-190	170-200	180-210	190-220	200-230	215-245				
		175-205	195-235	210-250	225-265	240-280	255-295	270-310				
				180-210	200-230	210-240	220-250	235-265				
				225-265	250-290	265-310	280-320	295-335				
								230-300	240-320	260-340	280-360	
								290-370	300-400	325-425	350-450	
									255-335	275-355	295-375	330-410
									320-420	345-445	370-470	410-510
				280-320	290-330	300-350	310-360	330-375				
				300-370	350-410	370-430	390-450	410-470				
								380-420	360-405	370-450		
								380-480	430-530	480-580		
									390-430	365-470	385-490	450-530
									480-560	510-610	540-640	590-690

Note that these capacities are in metric tph and the settings are for open circuit crushing of dry material with a density of 1600 kg/m³ and with material finer than the closed-side setting removed from the crusher feed. All of this data is intended as a general guide only. For any given material, Terex Jaques must confirm the tph and settings, because the crushability of material can vary greatly depending on the work index, moisture content and feed grading. Those factors affect the crusher's grading and throughput. Also note that the information in the table above may itself be subject to change.

Checklist for Purchasing a Gyracone Cone Crusher

Terex Jaques Gyracone Cone Crushers		Why it matters
✓	Roller bearing eccentric.	Improved load carrying capacity and operating speed flexibility.
✓	Spherical spider bearing.	Longer life and constant geometric alignment.
✓	Fingertip closed-side setting control.	Quick adjustments to production requirements and for liner wear.
✓	Single accumulator.	Simple tramp iron relief system.
✓	High-power drive.	Ranging from 150kw (J35) to 335kw (J65). Power input relates to crusher output.
✓	Large crushing stroke.	Maximise production.
✓	Heavy duty construction.	Weight ranges from 11 tonnes (J35) to 45 tonnes (J65). More robust crushers means longer life.
✓	Automatic Crusher Management System (CMS).	Accurate product specs and high output with few operator adjustments. Full data-log history for analysis.
✓	Hardened spiral-cut gears.	Large power-carrying capacity. Less wear and longer life.
✓	Constant feed opening crushing chamber.	Full range of crushing profiles for all applications, giving constant feed opening technology for improved crusher operation.
✓	Variable stroke eccentric.	Allows the crusher to be configured in order to match stroke and speed for optimum production. Also gives the option to reconfigure the operating parameters if the crusher application is changed.
✓	Flexibility in operating speed.	Allows speed selection for optimum product specs and output.
✓	Extensive branch network providing spares and service support.	Greatly reduces downtime and lets you plan production confidently.
✓	Process knowledge of technical staff.	Expert help in integrating cone crushers into your plant.
✓	Proven in the field.	A factor in your Duty of Care in selecting equipment.



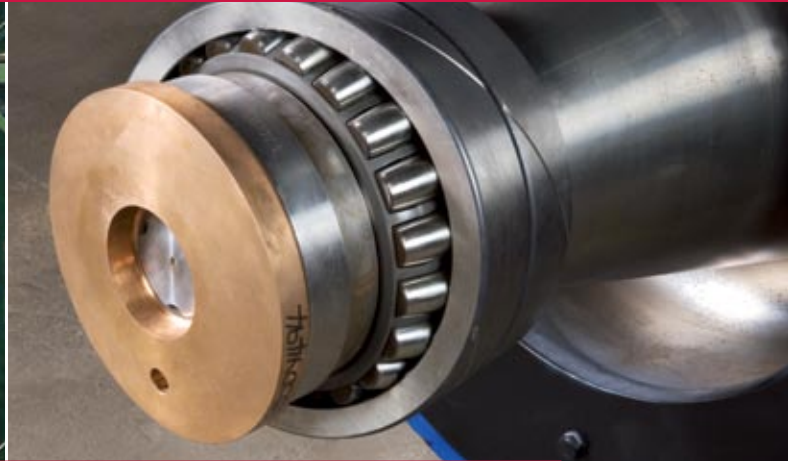

TEREX JAQUES GYRACONE CONE CRUSHERS

- ▲ Infinite adjustment under load
- ▲ Adjustable stroke
- ▲ Constant mainshaft alignment
- ▲ Enhanced tramp iron relief

The Terex Jaques product range also includes apron feeders, jaw crushers, vibrating screens, grizzlies and impactors. For more information about Gyracone Cone Crushers or other products, contact a Terex Jaques technical advisor.

AUSTRALIA

Email jaques@terex.com.au
Web www.terexjaques.com.au

Melbourne
Phone (+61 3) 8551 9300
Fax (+61 3) 8551 9364

Perth
Phone (+61 8) 9458 5566
Fax (+61 8) 9350 5534

Sydney
Phone (+61 2) 9604 6524
Fax (+61 2) 9604 9368

Brisbane
Phone (+61 7) 3630 0866
Fax (+61 7) 3630 1097

MALAYSIA

Kuala Lumpur
Phone (+60 3) 5631 6199
Fax (+60 3) 5631 6187
Email jaques@po.jaring.my

THAILAND

Bangkok
Phone (+66 2) 692 6666
Fax (+66 2) 692 6697
Email jaquesth@ksc.th.com