



TEREX JAQUES LABORATORY CRUSHERS

- ▲ Proven, robust design.
- ▲ Jaw Crushers and Roller Mills available.
- ▲ Includes support stand, discharge tray, drive and starter.

Jaques Laboratory Crushers are compact, robust and reliable units. Both Jaw Crusher and Roller Mill designs are available to meet all sampling requirements.

Each machine is backed by the Terex Jaques total after-market service and spare parts.

► Specifications

▼ Roller Mills

Laboratory Roller Mills are available in two sizes, 200mm diameter x 125mm wide and 300mm diameter x 150mm wide rolls.

Both units can be supplied as basic crushers to be incorporated into an existing laboratory layout or supplied as fully self contained units.

All rotating parts are well guarded and the crushing chamber is enclosed to minimise dust expulsion.

Model	200x125mm (8x5)	300x175mm (12x7)
Weight	340kg	1020kg
Electric Motors	2x1.1kW 6 Pole	2x2.2kW 8 Pole
Max. Speed of Crusher Pulley	210rpm	260rpm
Height	890mm	1184mm
Width	558mm	686mm
Length	850mm	1384mm

▼ Features

Feed hopper positioned at the optimum height.

- Allows easy tipping of feed material.

Support on adjustable rubber vibration dampers.

- Allows direct floor mounting without damaging the surface.

Provision of a DOL push button starter.

- Minimises electrical installation costs.

Includes support stand, discharge tray, drive and starter.

- Allows for simple installation.

1. Replaceable manganese steel side liners protect the crusher side frames.
2. Heavy duty SKF self-aligning spherical roller bearings.
3. Balanced vee-groove flywheel.
4. Fabricated mild steel frame, fully stress relieved.
5. Vernier setting adjustment enables rapid, fine adjustments to be made.
6. Toggle block with settings for fine or coarse crushing.
7. Direct on line starter.
8. T.E.F.C. Electric Motor
9. Safety toggle prevents damage to mechanism should uncrushable materials enter the crushing chambers.
10. Collection bin, feed hopper and delivery chute.
11. Work hardening, manganese steel jaw faces.

The Terex Jaques product range also includes apron feeders, jaw crushers, vibrating screens, grizzlies and impactors. For more information about Terex Jaques Laboratory Crushers or other products, contact a Terex Jaques technical advisor.

AUSTRALIA

Web www.terexjaques.com

Melbourne

Phone (+61 3) 8551 9300

Fax (+61 3) 8551 9364

Perth

Phone (+61 8) 9458 5566

Fax (+61 8) 9350 5534

Sydney

Phone (+61 2) 9604 6524

Fax (+61 2) 9604 9368

Brisbane

Phone (+61 7) 3630 0866

Fax (+61 7) 3630 1097

▼ Jaw Crushers

The Jaques Laboratory Single Toggle Jaw Crusher can be supplied in two sizes: 200x125mm (8x5 feed opening) and 300x175mm (12x7)

Each size can be supplied as either a basic crusher or as a fully equipped laboratory unit which is mounted on a stand, complete with feed hopper, collection tray, drive and starting equipment.

The 200x125mm unit is also available in a 200x100mm arrangement for an increased angle of nip and finer product.

Model	200x125mm (8x5)	300x175mm (12x7)
Weight	590kg	1190kg
Motor	4.0kW	5.5kW
Max. Speed of Crusher Pulley	400rpm	350rpm
Height	1150mm	1410mm
Width	560mm	700mm
Length	1035mm	1170mm
	CSS CAPACITY	CSS CAPACITY
	10mm 1.0 Tonne	25mm 4.2 Tonne
	6mm 0.75 Tonne	19mm 3.3 Tonne
	3mm 0.60 Tonne	12mm 1.5 Tonne
	1mm 0.45 Tonne	6mm 1.5 Tonne
		3mm 1.0 Tonne

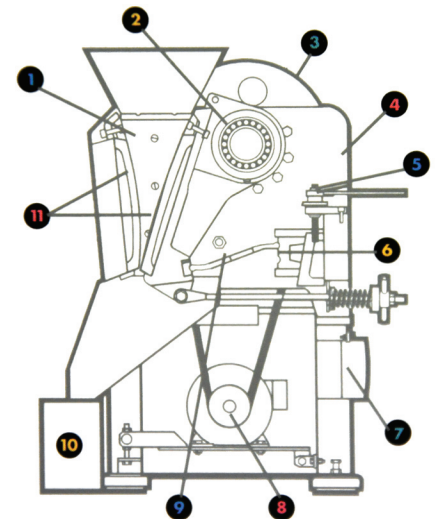

MALAYSIA

Kuala Lumpur

Phone (+60 3) 5631 6199

Fax (+60 3) 5631 6187

Email th.teo@terexjaques.com.my

THAILAND

Bangkok

Phone (+66 2) 3821 4761

Fax (+66 2) 3821 4760

Email pichet@jaquesthai.com